

MODEL: SHD-143 II
SHD-145 II
SHD-203 II
SHD-205 II



0AF04119
Copyright © October 17, 2002 DBI
Printed in U.S.A.

DECAL DESCRIPTIONS AND LOCATIONS



WARNING: Verify that all safety warning and operation decals are properly affixed to the unit and are clearly legible. Replace any decals that have been damaged or removed.



P/N 046128 (Blade Guard)



P/N 177588 (Blade Guard)



P/N 187052 (Blade Guard)



P/N 170333 (Water Pan)

PARTS LIST

Parts List Callout Designation:

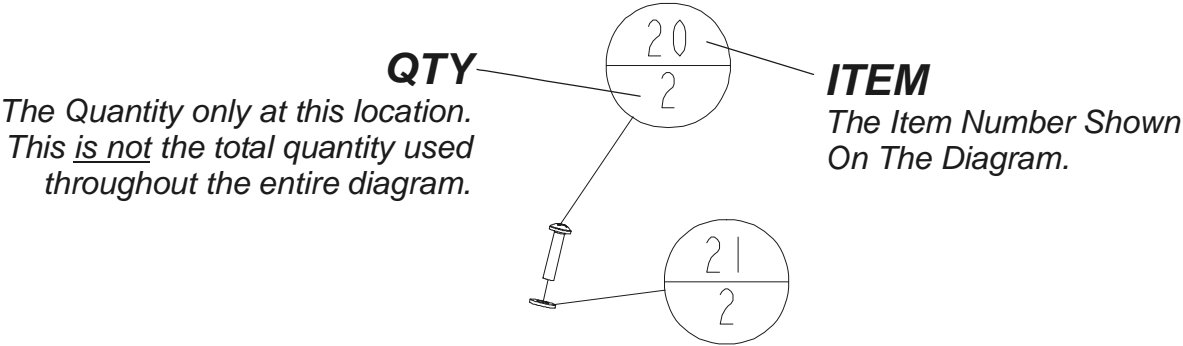

Diagram 1 – Frame Group

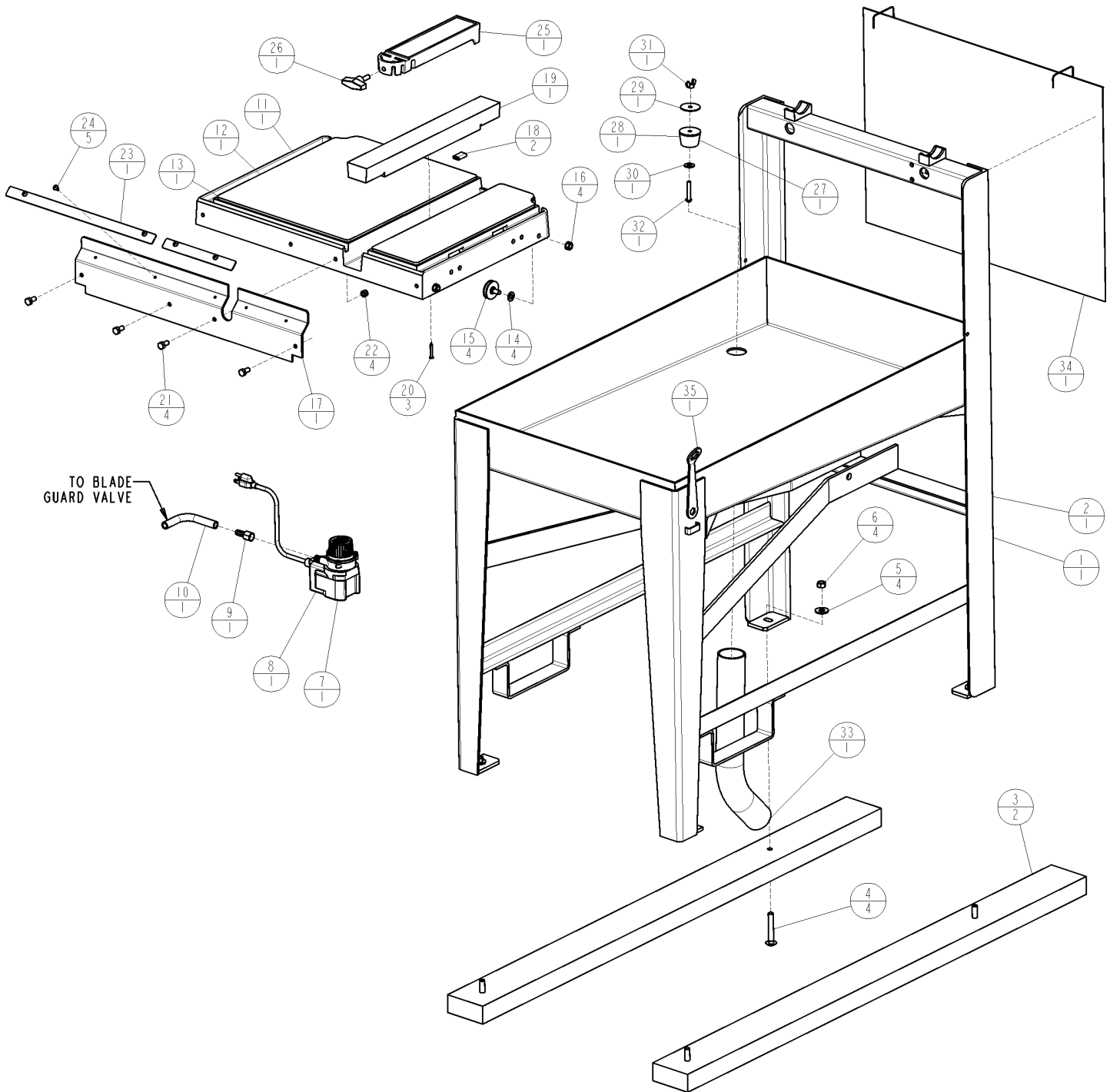

Diagram 1 – Parts List

ITEM	P/N	DESCRIPTION	QTY
1	-----	Frame Assembly	1
2	161586	Frame Weldment, PC Yellow	1
3	030884	Skid, 2 x 4 x 47.5 Lg	2
4	020022	Bolt, Carriage .375-16UNC x 2.50	4
5	020743	Washer, Flat .375 Dia	4
6	020136	Nut, Std Hex .375-16UNC	4
7	032605	Water Pump Assy, 115V G300 (Includes Items 9 & 10)	1
-	032606	Water Pump Assy, 230V-50Hz G300 (Incl Items 9 & 10)	1
8	-----	Water Pump (See Diagram 7)	1
9	030654	Adapter, 1/4 NPT x 3/8 Hose Barb	1
10	161776	Tubing, Vinyl 3/8 ID x 42 Inch	1
11	177893	Conveyor Cart Assy (Does Not Include Item 25)	1
12	-----	Conveyor Cart Bench Assy	1
13	-----	Conveyor Cart w/Top	1
14	020763	Washer, Flat .312 SAE	4
15	030822	Wheel	4
16	032366	Nut, Keps .313UNC	4
17	032368	Backstop, Conveyor Cart	1
18	170038	Vinyl Tubing, 3/8 ID	2
19	177894	Wood Insert, 15.87" Lg	1
--	032431	Wood Insert, 11.50" Lg (Older Model Conveyor Cart)	1
20	177904	Screw, Wood Rd Hd #8-32UNC x 1.25 Phil	3
21	020301	Capscrew, Hex Hd .250-20UNC x .625	4
22	020195	Locknut, Fiber .250-20UNC	4
23	177976	Decal, Ruler Set	1
24	020432	Screw, Pan Hd Slf Tap #10-24UNC x .38 Type D Phil	5 (Note 1)
25	030351	Guide, Measuring Assy (Includes Item 26)	1 (Note 2)
26	180987	Knob, Tee 5/16-18UNC x 1.00 (Later Models)	1 (Note 2)
--	020600	Thumb Screw, .312-18UNC x 1.00 (Early Models)	1 (Note 2)
27	-----	Drain Plug Assembly	1
28	-----	Stopper, Lab	1
29	-----	Washer, Flat 1.50 OD x .281 ID x .062 Thk	1
30	-----	Washer, Flat .250 Dia	1
31	-----	Nut, Wing .250-20UNC Type A	1
32	-----	Screw, Mach Rd Hd .250-20UNC x 1.5	1
33	032342	Drain Hose	1
34	032372	Splash Curtain	1
35	177383	Wrench, 1/2 x 3/4	1

NOTES:

1. Screw (Item 24) Used Only With Aluminum Rulers That Were Used On Early Models (Aluminum Rulers Are No Longer Available). The New Ruler Set (Decal) Requires No Mounting Screws.
2. Item 26: Thumb Screw (P/N 020600) Was Used On Early Models, and is Interchangeable with the Knob (P/N 180987) Used On Later Models. Item 25: Measuring Guide Assy (From Service Parts) Could Contain Either The Knob Or The Thumb Screw.

Diagram 2 – Foot Pedal Group

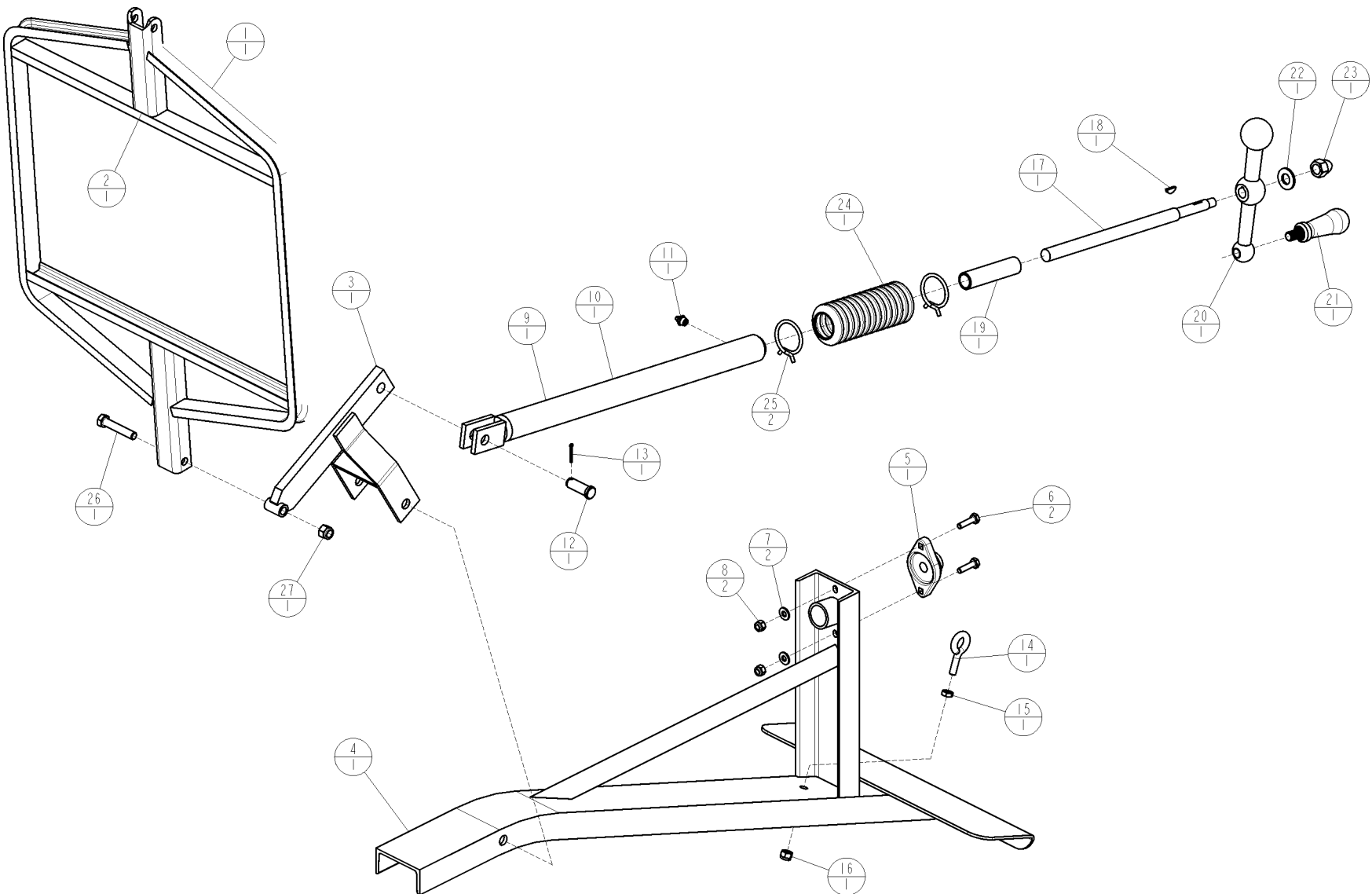

Diagram 2 – Parts List

ITEM	P/N	DESCRIPTION	QTY
1	-----	Tilt Bar Assy	1
2	175334	Tilt Bar Weldment	1
3	175333	Tilt Adjust Yoke	1
4	175332	Foot Pedal Weldment	1
5	040141	Flange Bearing	1
6	020306	Capscrew, Hex Hd .250-20UNC x 1.0	2
7	020762	Washer, Flat .250 SAE	2
8	020195	Locknut, Fiber .250-20UNC	2
9	032590	Adjustment Nut Assy (Includes Item 11)	1
10	-----	Adjustment Nut Weldment	1
11	040139	Fitting, Grease 1/8 NPT	1
12	160164	Pin, Clevis .50 Dia x 1.13 Lg	1
13	020612	Pin, Cotter .094 x .75	1
14	060305	Eyebolt, .312-18UNC X 1.00	1
15	020169	Nut, Jam Hex Hd .312-18UNC	1
16	020197	Locknut, Fiber .3125-18UNC	1
17	032570	Adjustment Screw	1
18	020010	Key, Woodruff #405	1
19	032580	Stop Sleeve	1
20	032240	Crank Handle Assembly (Includes Item 21)	1
21	032250	Handle Assy, Revolving	1
22	020766	Washer, Flat .500 SAE	1
23	020211	Nut, Acorn .500-13UNC	1
24	040184	Rubber Boot, 4 Inch (27 ribs)	1
25	020261	Clamp, Hose A22	2
26	020509	Capscrew, Hex Hd .375-16UNC x 2.00	1
27	020199	Locknut, Fiber .375-16UNC	1
28	030810	Spring, Foot Pedal	2

Diagram 3 – Foot Pedal Attaching Group

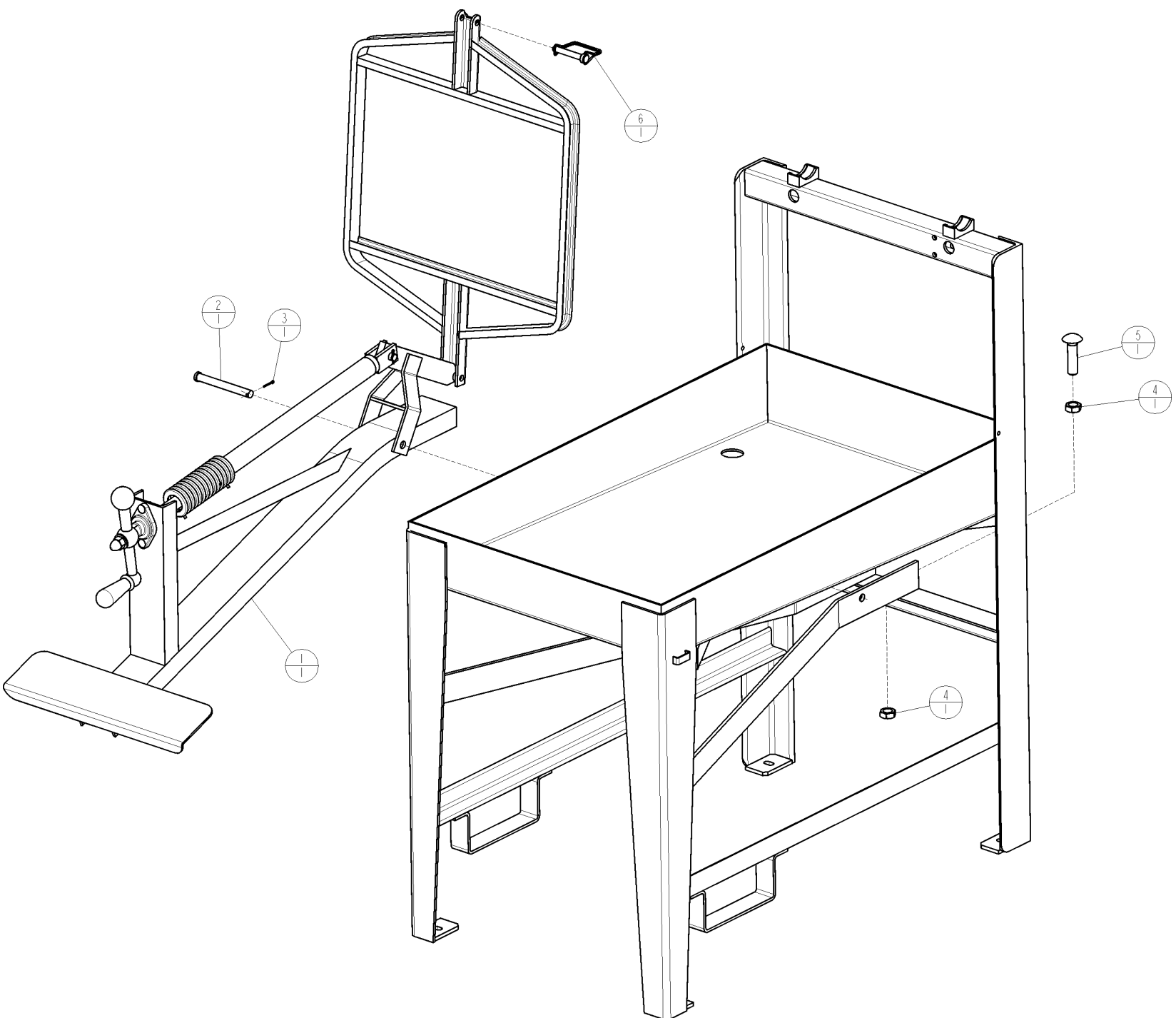

Diagram 3 – Parts List

ITEM	P/N	DESCRIPTION	QTY
1	-----	Frame Parts (See Diagram 2)	1
2	162154	Foot Pedal Pin	1
3	020612	Pin, Cotter .094 x .75	2
4	020306	Capscrew, Hex Hd .250-20UNC x 1.0	2
5	020762	Washer, Flat .250 SAE	2
6	020175	Nut, Jam Hex Hd .625-11UNC	2
7	020024	Bolt, Carriage .625-11UNC x 2.50	1
8	160080	Pin, Snapper .375 Diameter	1

Diagram 4 – Head Platform Group

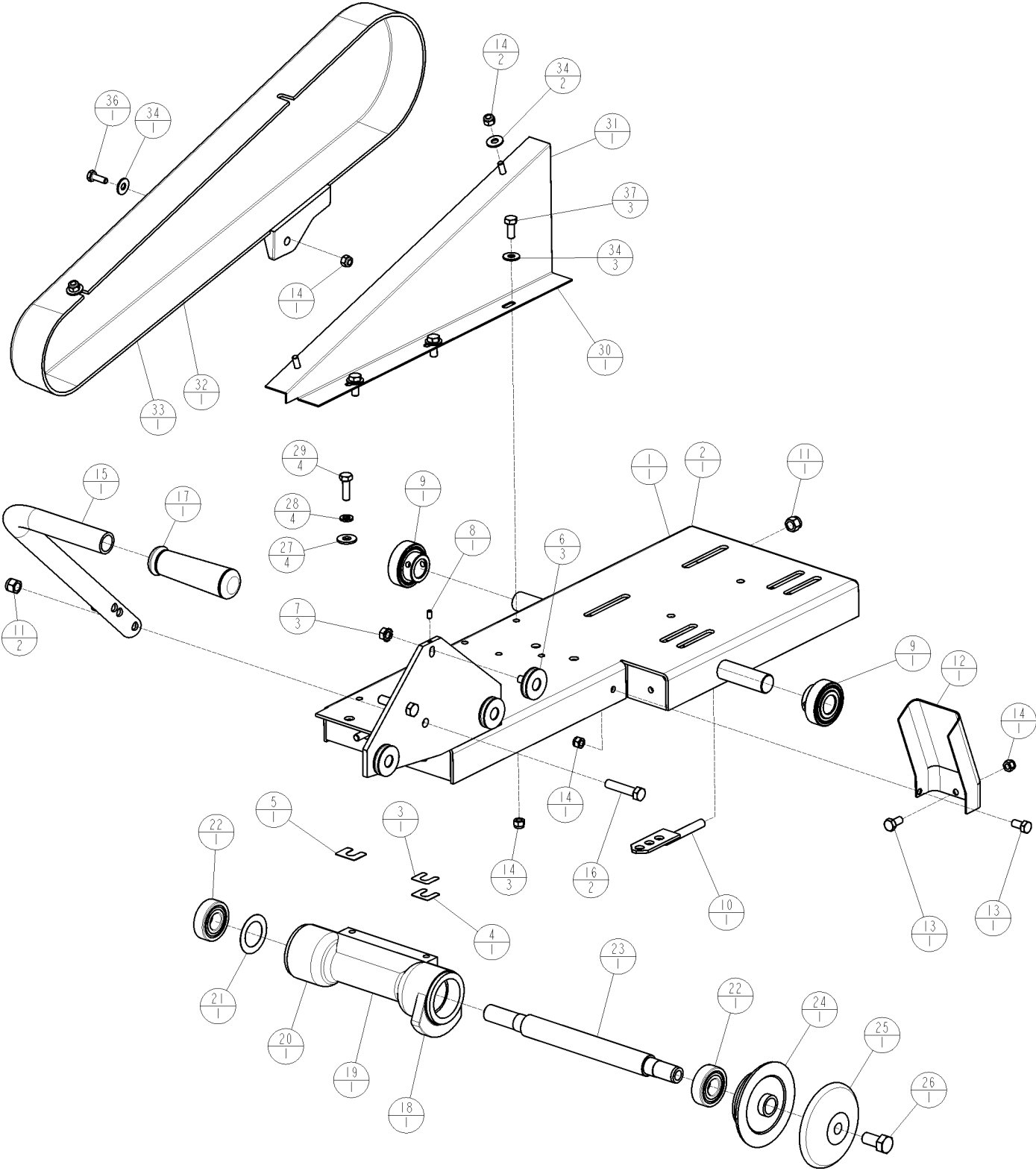

Diagram 4 – Parts List

ITEM	P/N	DESCRIPTION	QTY
1	-----	Cutting Head Assy	1
2	180053	Platform Weldment	1
3	032501	Shim, Brass .005 Thick	1 (Note 3)
4	032502	Shim, Brass .015 Thick	1 (Note 3)
5	032503	Shim, Brass .020 Thick	1 (Note 3)
6	030822	Wheel	3
7	032366	Nut, Keps .313UNC	3
8	020548	Screw, Set Soc Cup Pt #10-24UNC x .375	1
9	030580	Bearing, Head Pivot	2
10	177696	Draw Bolt, 3/8-16UNC	1
11	020199	Locknut, Fiber .375-16UNC	3
12	180054	Shield, Blade Guard	1
13	020301	Capscrew, Hex Hd .250-20UNC x .625	2
14	020195	Locknut, Fiber .250-20UNC	2
15	186215	Handle	1 (Note 4)
16	020380	Capscrew, Hex Hd .375-16UNC x 1.75	2
17	139568	Grip, Handle	1 (Note 4)
18	195023	Blade Shaft Assy w/Outer Flange (Incl Items 19-29)	1 (Note 5)
19	-----	Shaft, Blade w/Hsg Assy	1 (Note 5)
20	195020	Housing, Shaft	1 (Note 5)
21	030004	Washer, Finger Spring	1
22	139273	Bearing w/seal	2
23	195017	Shaft, Blade	1 (Note 5)
24	177973	Collar, Inner	1
25	030951	Outer Collar	1
26	020378	Capscrew, Hex Hd .500-20UNF x 1.00	1
27	020742	Washer, Flat .313 Dia	4
28	020785	Lockwasher, Split .313	4
29	020316	Capscrew, Hex Hd .312-24UNF x 1.00	4
30	-----	Belt Guard Group	1
31	180055	Bracket, Belt Guard, PC Black	1
32	170320	Belt Guard, Yellow	1
33	-----	Belt Guard	1
34	020741	Washer, Flat .250 Dia	6
35	020195	Locknut, Fiber .250-20UNC	6
36	020370	Capscrew, Hex Hd .250-20UNC x .75	1
37	020302	Capscrew, Hex Hd .250-20UNC x .75	3

NOTES:

3. Shims are listed as required to align bladeshaft. Order qty. desired for alignment of a specific saw.
4. Handle and Grip Effective November 1999. **Refer to Instruction Sheet 0A7810 for further information**, for retro-fitting of new handle onto older units. Note that Older Handle (P/N 060390 – Not Shown) is a Straight Pipe, and is No Longer Available (Replaced with Kit P/N 186218). Older Grip (P/N 043935 – Not Shown), is for use with P/N 060390 (Old Handle) and is still available.
5. **P/N 195023 Blade Shaft Assy Effective S/N 380821** (One Earlier Unit S/N 380814). First Production Unit Built 04September 2002. Note that new Shaft (Item 23), and Housing (Item 20) **ARE NOT** for use on units before the Effective S/N, unless they have had this blade shaft assembly field installed (through Service Parts). **Refer to Instruction Sheet 0A7873 for further information**, and how to identify new / old blade shaft and assemblies (due to this change).

Diagram 5 – Head Platform Attaching Group

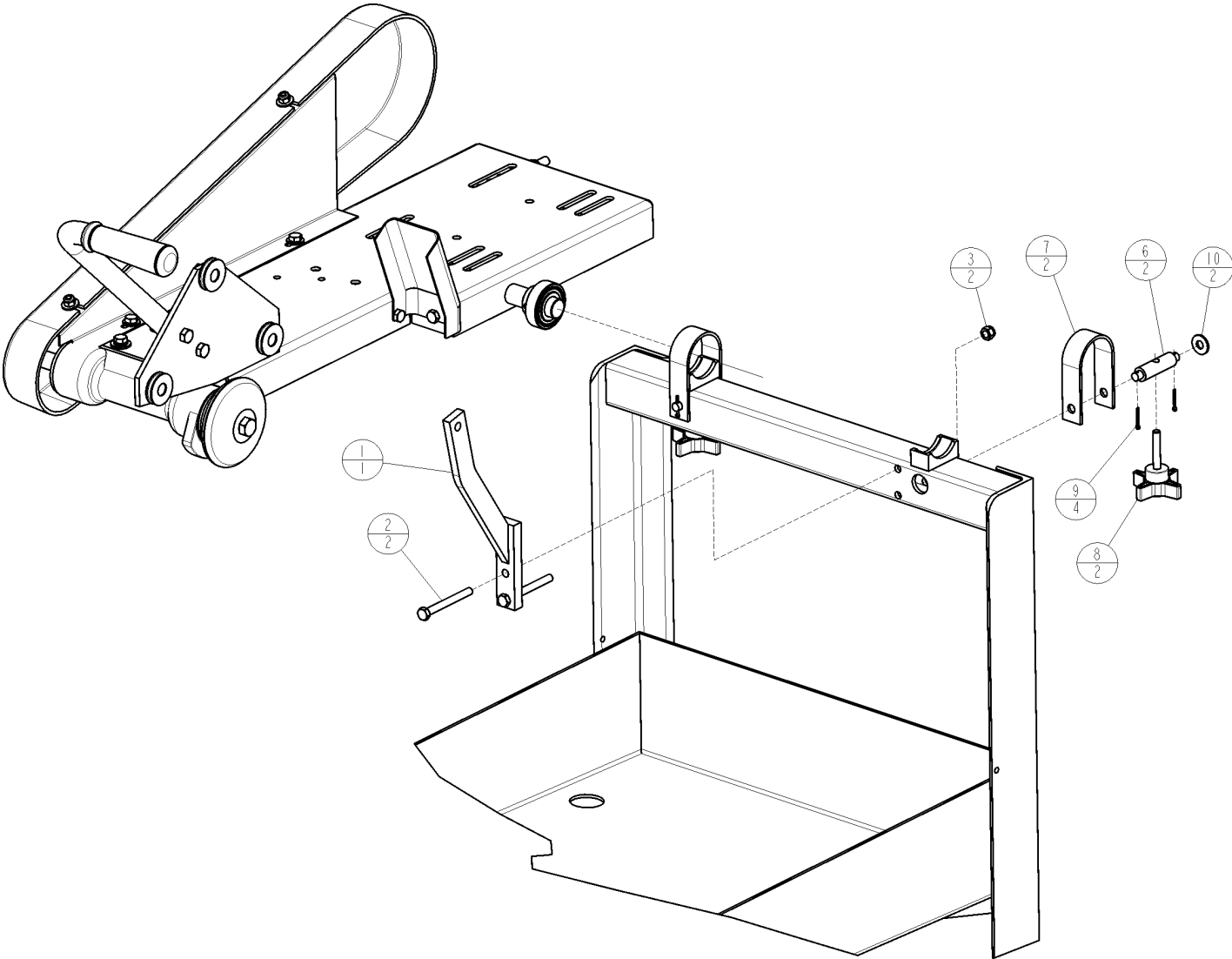

Diagram 5 – Parts List

ITEM	P/N	DESCRIPTION	QTY
1	175335	Tilt Arm Weldment	1
2	020374	Capscrew, Hex Hd .312-18UNC x 3.00	2
3	020197	Locknut, Fiber .3125-18UNC	2
4	020306	Capscrew, Hex Hd .250-20UNC x 1.0	2
5	020762	Washer, Flat .250 SAE	2
6	032471	Bar, Bearing Clamp	2
7	032660	Clamp, Bearing	2
8	177721	Knob, 1.75 x 5/16-18UNC-2A	2
9	020612	Pin, Cotter .094 x .75	4
10	020742	Washer, Flat .313 Dia	2

Diagram 6 – Blade Guard, 14 inch & 20 Inch

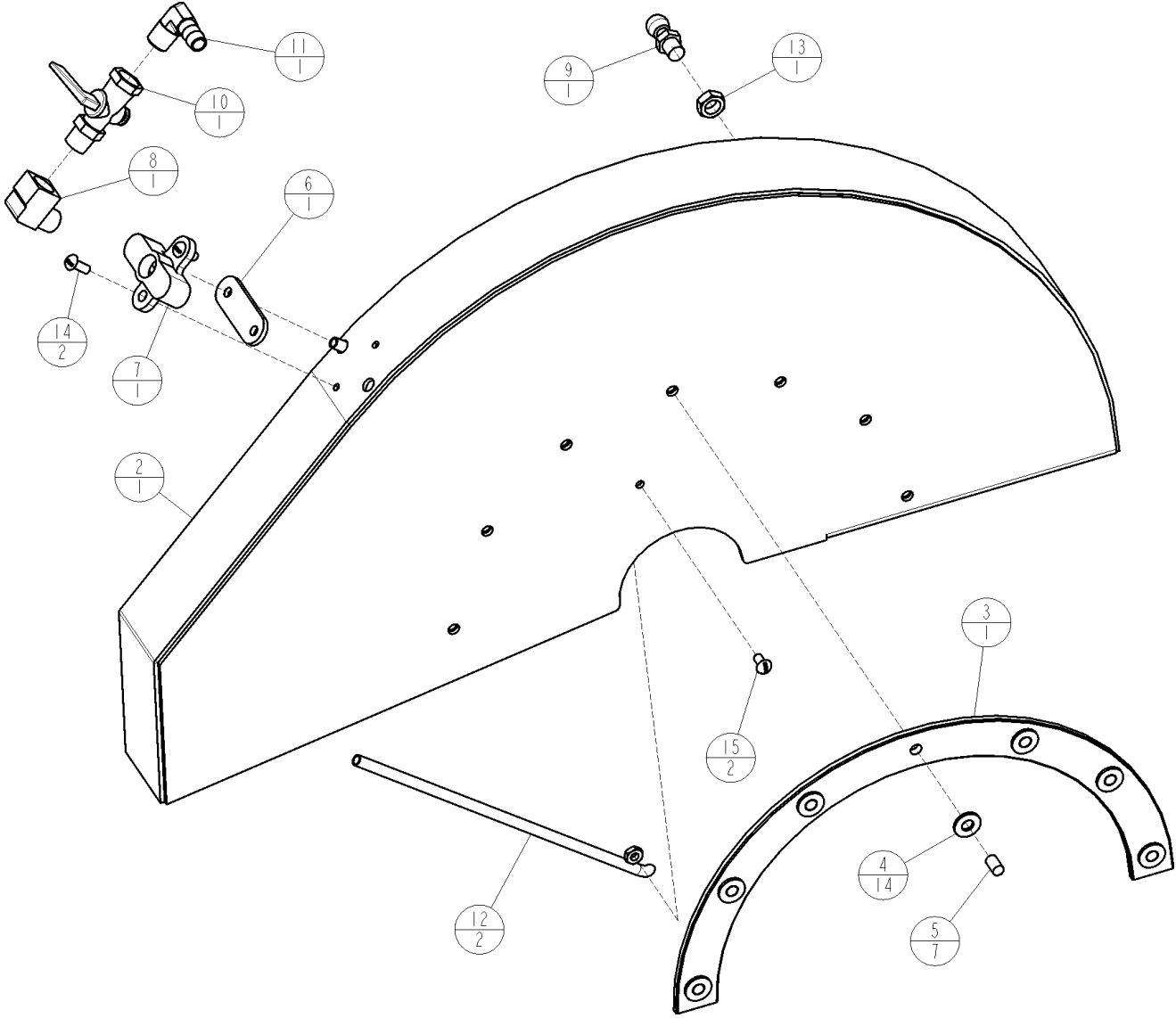

Diagram 6 – Parts List

ITEM	P/N	DESCRIPTION	QTY
1	170331	Blade Guard Assy-20", PC Yellow (Incl. Items 2-15)	1
	170330	Blade Guard Assy-14", PC Yellow (Incl. Items 2-15)	1
2	-----	Blade Guard Weldment, 20"	1
	-----	Blade Guard Weldment, 14"	1
3	030860	Track	1
4	020762	Washer, Flat .250 SAE	14
5	020701	Pop Rivet, USM #D88BS	7
6	030875	Gasket, Water Manifold	1
7	030870	Manifold, Water	1
8	020813	Elbow, 90° Street, 1/4NPT male x 1/4NPT female	1
9	031039	Machined Ball Stud	1
10	090578	Water Valve, 1/4NPT male by 1/4NPT female	1
11	161176	Elbow, 90 Deg Barb, .375 Hose x .25 NPT	1
12	030891	Water Tube Assembly, 20"	2
	030865	Water Tube Assembly, 14"	2
13	020171	Nut, Jam Hex Hd .375-24UNF RH	1
14	020425	Screw, Mach Rd Hd #10-32UNF x .50	2
15	020424	Screw, Mach Rd Hd #10-32UNF x .375	2

Diagram 7 – Water Pump Group

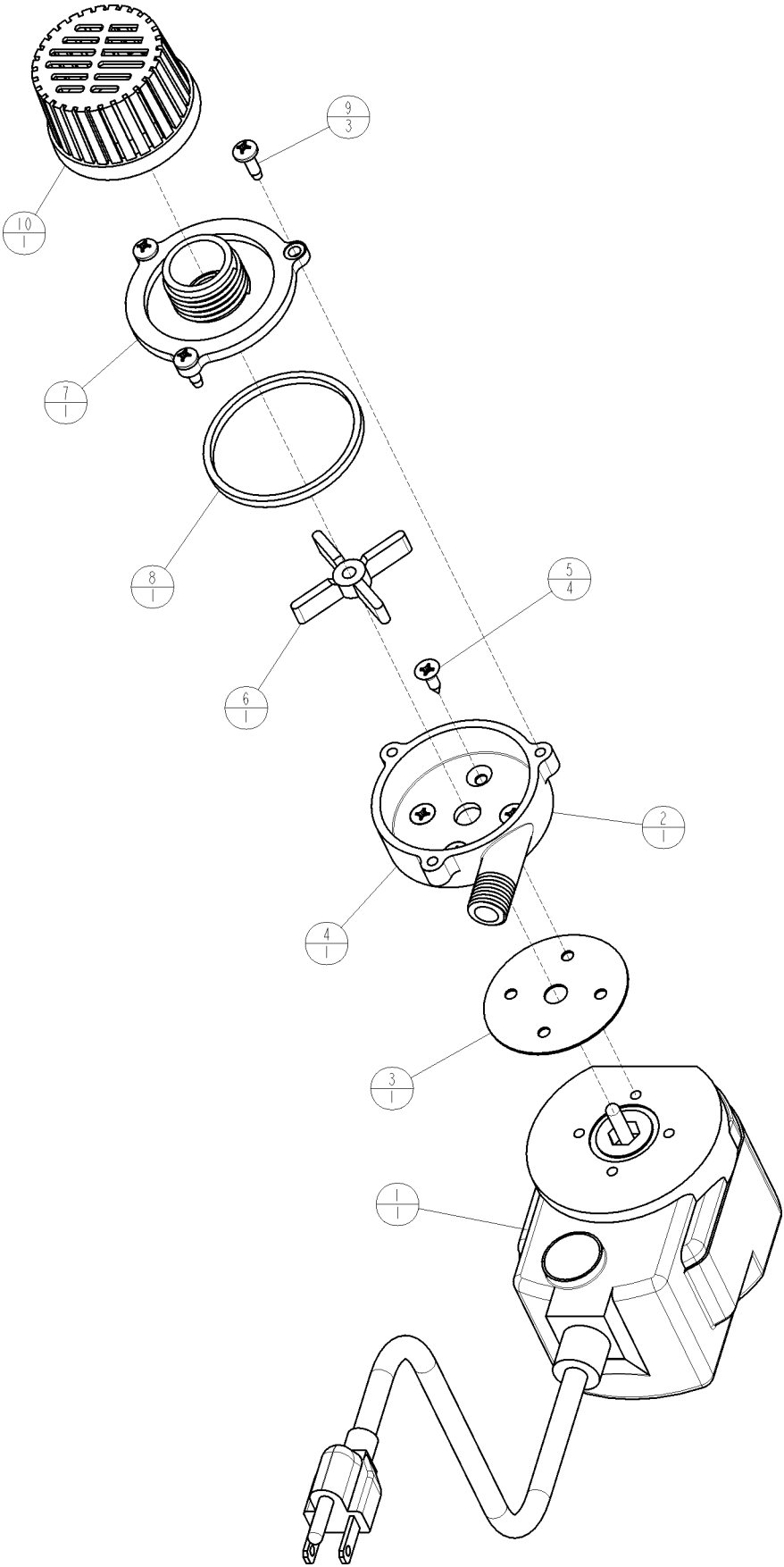

Diagram 7 – Parts List

ITEM	P/N	DESCRIPTION	QTY
1	032088	Water Pump, 115V (Complete)	1
-	032087	Water Pump, 230V, 50Hz (Complete)	1
2	032124	Repair kit, G300 Water Pump (Includes Items 3-10)	1
3	032094	Gasket, G300 & G100	1
4	032093	Volute, G300	1
5	032123	Screw, Flat Hd Slf Tap #8-18 x 0.50	4
6	032072	Impeller, G300	1
7	161490	Front Plate, G300	1
8	032095	O-Ring, G300	1
9	032122	Screw, Rd Hd Slf Tap #8-18 x 0.50	3
10	050171	Screen, G300 & G100	1

Diagram 8 – Motor Group, 3HP & 5 HP

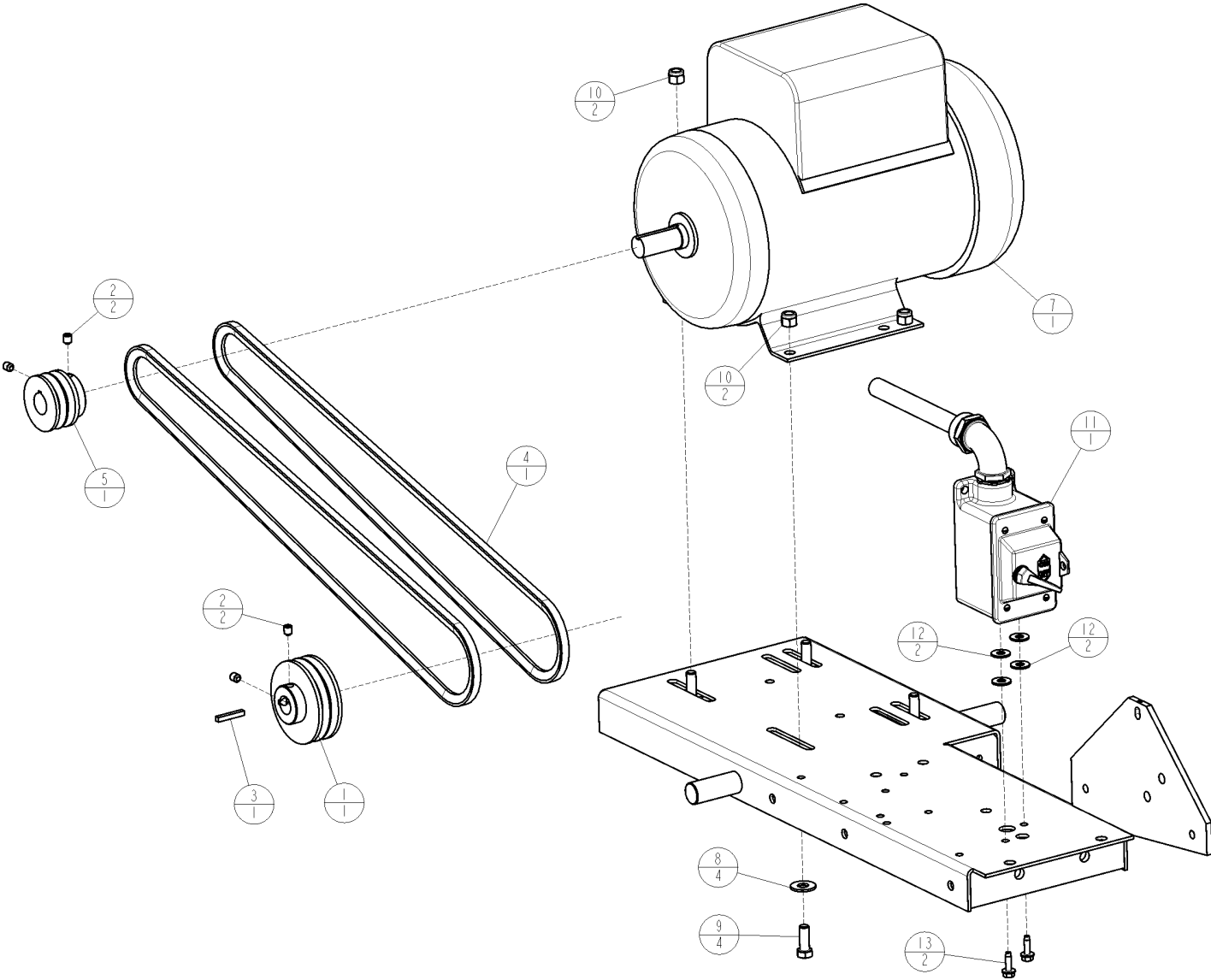

Diagram 8 – Parts List

17 October 2002

ITEM	P/N	DESCRIPTION	QTY	
1	030921	Pulley, 2G3V3.35-.75 (Incl Item 2) (14" & 20", 60Hz)	1	
-	060105	Pulley, 2G3V2.80-.75 w/ Hub (14", 50Hz)	1	
-	060106	Pulley, 2G3V3.15-.75 w/ Hub (20", 50Hz)	1	
2	020550	Screw, Set Soc Cup Pt .312-18UNC x .375	4	
3	020062	Key, Square .188 x 1.25 Lg	1	
4	030925	V-Belt, 3VX530 (Set of 2)	1	
5	030931	Pulley, 2G3V3.00 - .875 (Incl Item 2) (14", 60Hz)	1	
-	030906	Pulley, 2G3V2.25 - .875 (Incl Item 2) (20", 60Hz)	1	
-	030902	Pulley, 2G3V3.15 - .875 Bore w/Hub (14", 50Hz)	1	
-	060139	Pulley, 2G3V2.65 - .875 (Incl Item 2) (20", 50Hz)	1	
6	020550	Screw, Set Soc Cup Pt .312-18UNC x .375	2	
7	169622	Motor, 5hp 208-230/60Hz/1 Phase	1	
-	000923	Motor, 5hp 208-230/460/60Hz/3 Phase	1	
-	169656	Motor, 3hp 115/208-230/60Hz/1 Phase	1	
-	000806	Motor, 3hp 208-230/460/60Hz/3 Phase	1	
8	020743	Washer, Flat .375 Dia	4	
9	020323	Capscrew, Hex Hd .375-16UNC x 1.00	4	
10	020199	Locknut, Fiber .375-16UNC	4	
11	030071	Switch Assy, 3 Phase Only	1	(Note 6)
-	180810	Switch Assy, 1 Phase Only	1	(Note 7)
12	020741	Washer, Flat .250 Dia	4	
13	020489	Screw, HH Wash Self Tap .25-20UNC x .75	2	

NOTES:

- DO NOT** use part number 030071 Switch Assy (3 phase) on the 5hp-3 Phase Motor if it is set to 230 Volts. Use only on 3hp-3 Phase motor set to 230V or 460V and 5hp-3 Phase Motor set to 460V or 575V.
- See Diagram 9 for service parts.

Diagram 9 – P/N 180810 Switch Assy, 3 hp & 5 hp / 1 Phase / 60 Hz Motors

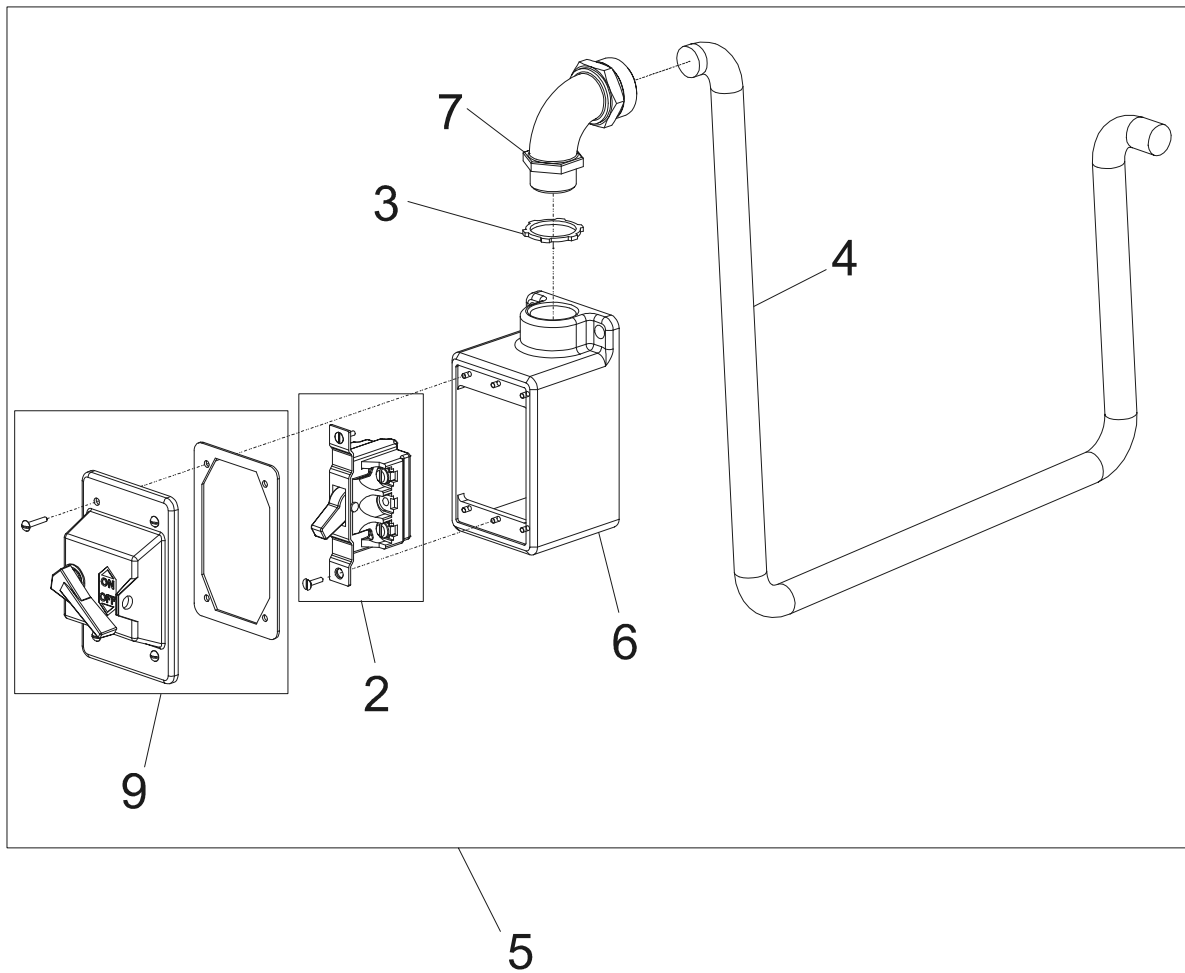

Diagram 9 Parts List: Contents of P/N 180810 Switch Assy (For 3 hp & 5 hp 1 Phase Motors Only)

Item	Qty	Part No.	Description
1	4	030085	Connector, Fork, 12-10Ga (Not Shown Above)
2	1	161581	Switch, 30A, 250V (for 3 hp & 5 hp, 1 Phase Motors Only)
3	1	176953	Locknut, 3/4" Conduit
4	1	180809	Cable, #12,-5 Conductor x 33" Long
5	1	180810	Switch Assy, Motor
6	1	180814	Switch Box, 3/4"NPT (Modified)
7	1	180815	Connector, 3/4"NPT x 90 Degree
8	1	180818	Connector, Ring Terminal, #8, 12-10, Insulated (Not Shown Above)
9	1	032541	Cover Assy, Switch Box – Includes Gasket & four #6-32UNF Screws
10	2	020489	Screws, .250-20UNC x .75" Lg (Not Shown –Use To Install Switch Assy to Machine)
11	1	0A7830	Instruction Sheet, Switch Assy Installation (Not Shown Above)

Note: Refer To Instruction Sheet 0A7830 for Installation of 180810 Switch Assy.

Diagram 10 – Parts List

ITEM	P/N	DESCRIPTION	QTY
1	001265	Motor, 7.5hp 230V/460V 60 Hz, 3 Phase	1
-	001257	Motor, 7.5hp 575V 60 Hz, 3 Phase	1
-	162287	Motor, 7.5hp 415V 50 Hz, 3 Phase	1
-	001270	Motor, 7.5hp 220V-380V 50 Hz, 3 Phase	1
2	020743	Washer, Flat .375 Dia	3
3	020323	Capscrew, Hex Hd .375-16UNC x 1.00	4
4	020199	Locknut, Fiber .375-16UNC	4
5	041113	Pulley, 3G3V3.35OD x .75 Bore (Includes Item 9)	1
6	030920	Pulley, 3G3V2.25 ODx.875 ID (20", 60Hz) (Incl Itm 10)	1
-	030916	Pulley, 3G3V3.00 ODx.875 ID (14", 60Hz) (Incl Itm 10)	1
7	030930	V-Belt, 3VX530 (Set of 3)	1
8	020062	Key, Square .188 x 1.25 Lg	1
9	020541	Screw, Set Soc Cup Pt .250-20UNC x .375	2
10	020550	Screw, Set Soc Cup Pt .312-18UNC x .375	2

Diagram 11 – Motor Starter (On / Off Switch) – 7.5 HP Motor

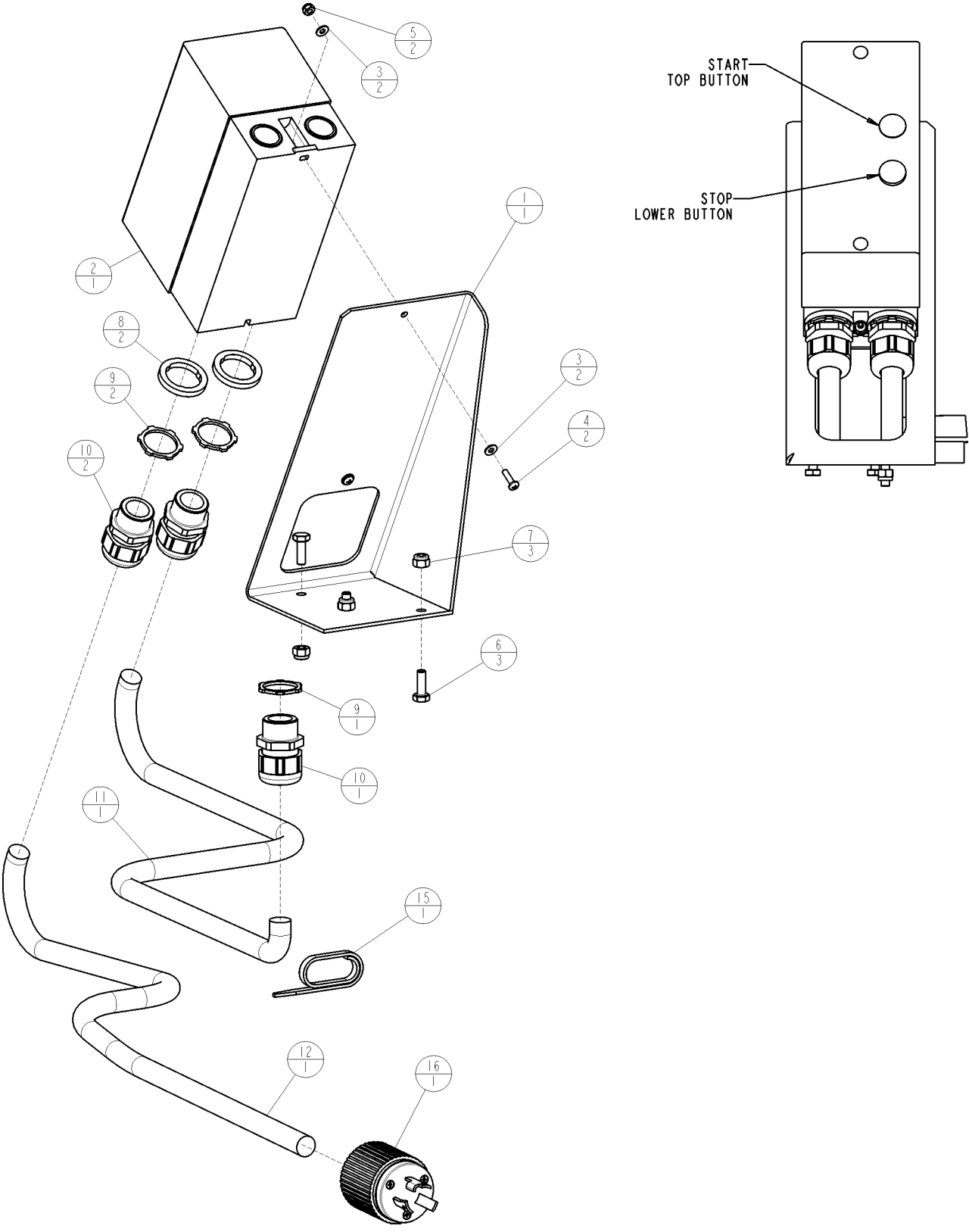

Diagram 11 – Parts List

ITEM	P/N	DESCRIPTION	QTY
1	190069	Bracket, Switch Box	1
2	186252	Starter Box, 7.5hp/3ph/575V	1 (Note 8)
	190102	Starter Box, 7.5hp/3ph/460V	1 (Note 8)
	190103	Starter Box, 7.5hp/3ph/230V	1 (Note 8)
3	197290	Washer, Flat M4	4
4	197293	Screw, Mach Pan Hd M4 x 0.70 x 16mm	2
5	167485	Locknut, Fiber M4 x 0.70	2
6	020370	Capscrew, Hex Hd .250-20UNC x .75	3
7	020195	Locknut, Fiber .250-20UNC	3
8	176933	Sealing Ring, 3/4 Conduit	2
9	176953	Locknut, 3/4 Conduit	3
10	182024	Strain Relief, 3/4 NPT	3
11	182018	Cord, Type SO - 12/4 x 38" (To Motor)	3.17 Feet
12	182018	Cord, Type SO - 12/4 x 42" (To plug)	3.50 Feet
13	090556	Connector, Wire, Yellow, 18-10 AWG	6
14	182021	Terminal Ring, Insulated #10 x 12-10GA	1
15	197101	Wire Tie, .094 x 8.0 Lg (Cord To Head Platform)	1
16	-----	Plug, Customer Supplied	1

NOTES:

- See Wiring Diagrams (Diagrams 17-21) To Verify Proper Motor / Switch Box Combination.

Diagram 12 – Wheel Around Kit (Field Installed Accessory)

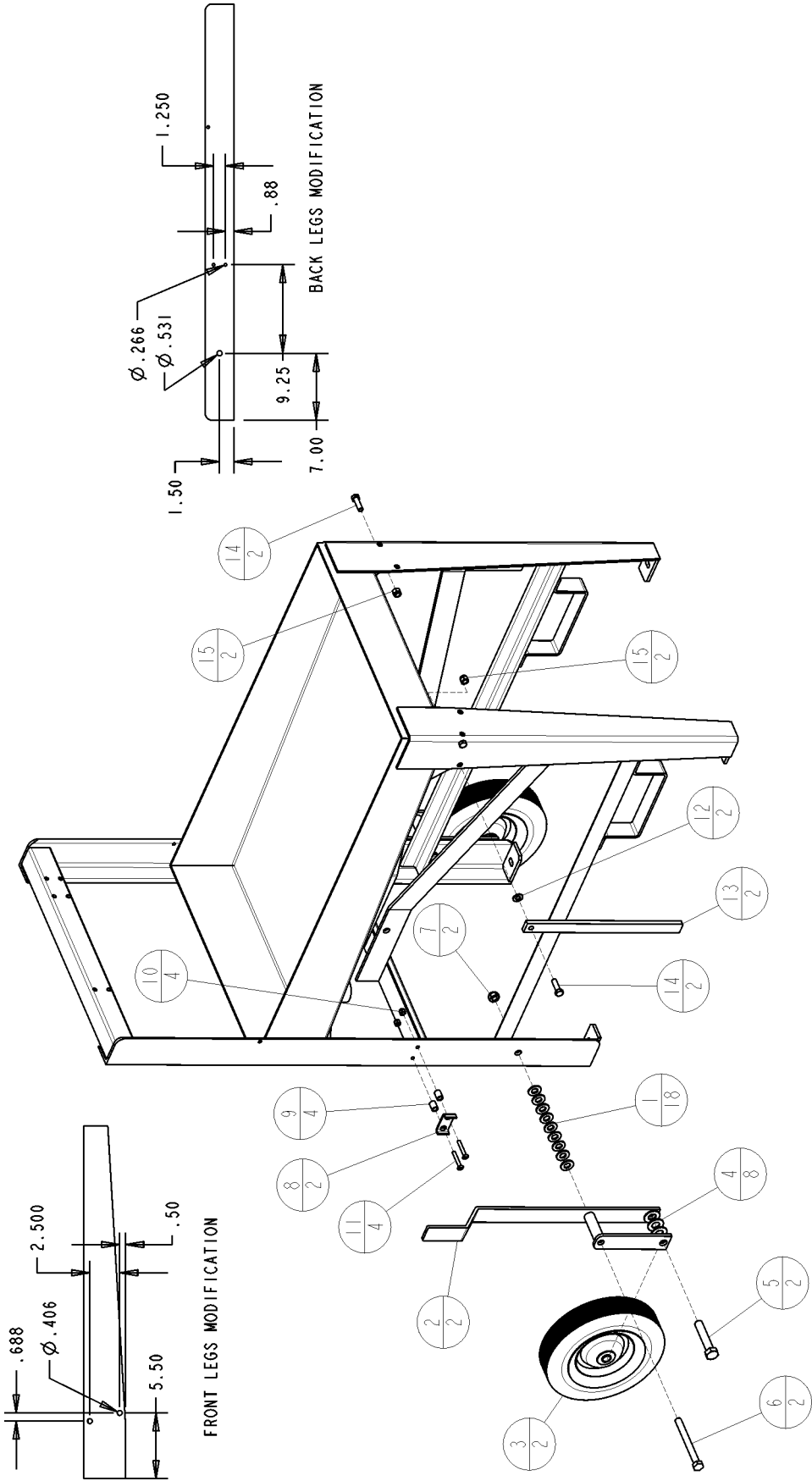

Diagram 12 – Parts List

ITEM	P/N	DESCRIPTION	QTY
1	020766	Washer, Flat .500 SAE	18
2	034005	Lever Weldment	2
3	034002	Wheel, 10 Dia x 2 3/8 x 5/8 Bore	2
4	020767	Washer, Flat .625 SAE	8
5	020361	Capscrew, Hex Hd .625-11UNC x 3.25	2
6	020352	Capscrew, Hex Hd .500-13UNC x 5.00	2
7	020201	Locknut, Fiber .500-13UNC	2
8	034003	Stop Plate	2
9	167742	Plastic Spacer	4
10	020195	Locknut, Fiber .250-20UNC	4
11	195005	Screw, Mach Ft Hd .250-20UNC x 1.50	4
12	020764	Washer, Flat .375 SAE	2
13	034004	Hand Lever	2
14	048740	Capscrew, Hex Hd .375-16UNC x 1.25	4
15	020199	Locknut, Fiber .375-16UNC	4

Diagram 13 – Wiring Diagram 5 hp / 208-230V / 1 Phase / 60Hz Motor (169622)

17 October 2002

DBI PART NO. 169622
 (WAS 161492)
 BALDOR SPEC. NO.: 36G628W568G1
 5 HP, 3450 RPM, T.E.F.C.
 208-230V, 60 Hz, 1 PHASE
 21.5-20 FULL LOAD AMPS
 INS. CLASS: F
 CODES: NEMA => L; KVA => J

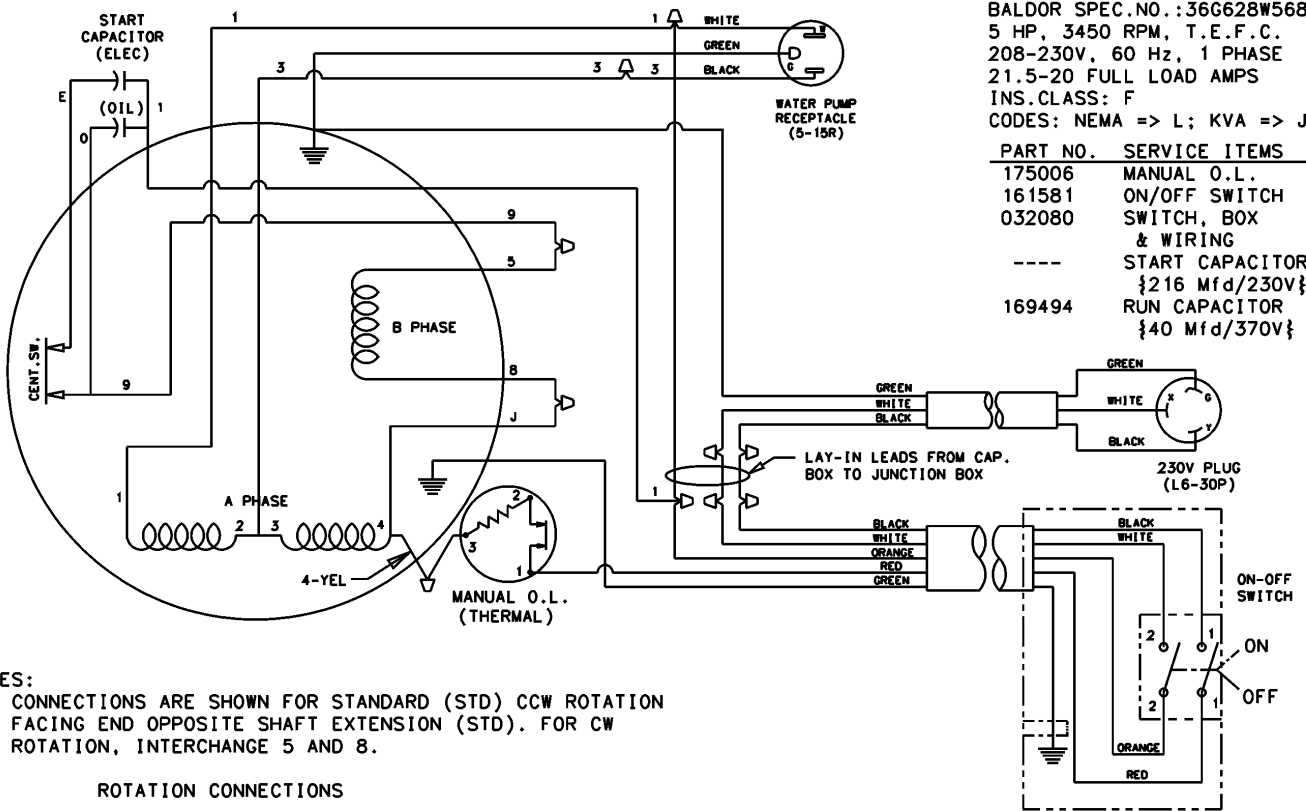

NOTES:

1. CONNECTIONS ARE SHOWN FOR STANDARD (STD) CCW ROTATION FACING END OPPOSITE SHAFT EXTENSION (STD). FOR CW ROTATION, INTERCHANGE 5 AND 8.

2. ROTATION CONNECTIONS

	JOIN	JOIN	ROT.	
STD.	9, 8	J, 5	CCW	
OPP.	9, 5	J, 8	CW	

Diagram 14 – Wiring Diagram 5hp/ 208V-230V/460V/3 Phase/ 60Hz Motor (000923)

Contact Factory For Wiring Diagram

Diagram 15 – Wiring Diagram 3 hp/ 115V/208-230V /1 Phase/60 Hz Motor (169656)

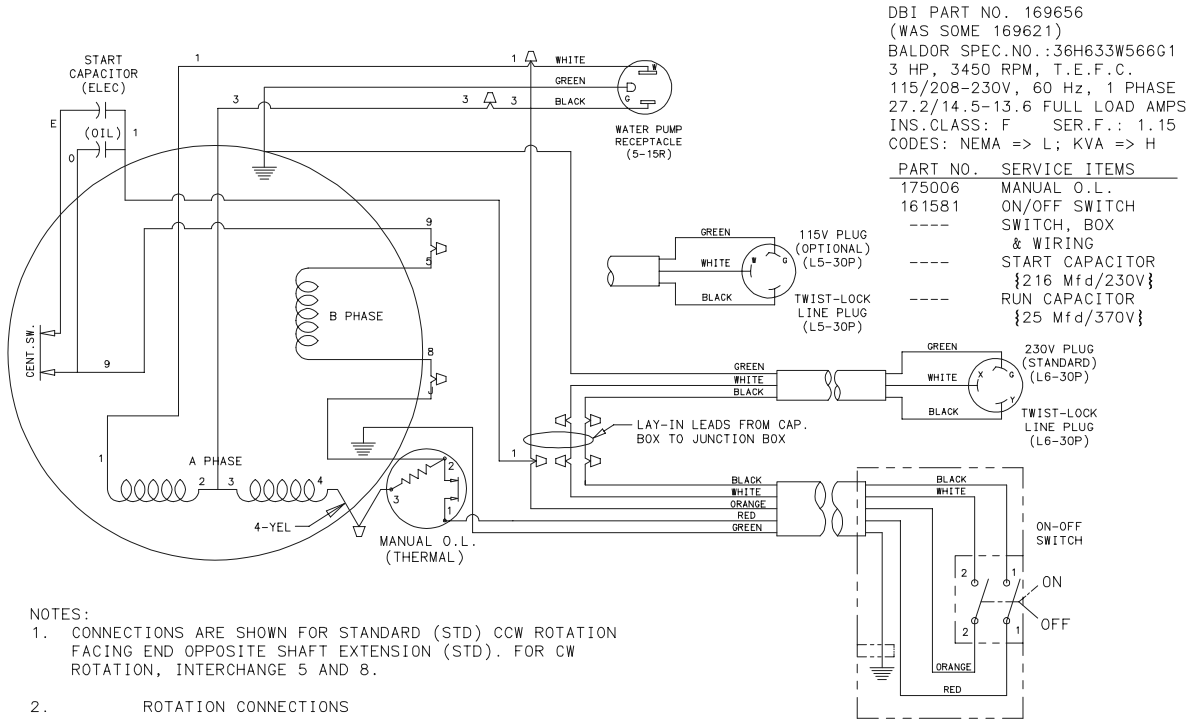

DBI PART NO. 169656
 (WAS SOME 169621)
 BALDOR SPEC. NO.: 36H633W566G1
 3 HP, 3450 RPM, T.E.F.C.
 115/208-230V, 60 Hz, 1 PHASE
 27.2/14.5-13.6 FULL LOAD AMPS
 INS. CLASS: F SER.F.: 1.15
 CODES: NEMA => L; KVA => H

PART NO.	SERVICE ITEMS
175006	MANUAL O.L.
161581	ON/OFF SWITCH SWITCH, BOX & WIRING
----	START CAPACITOR {216 Mfd/230V}
----	RUN CAPACITOR {25 Mfd/370V}

- NOTES:
1. CONNECTIONS ARE SHOWN FOR STANDARD (STD) CCW ROTATION FACING END OPPOSITE SHAFT EXTENSION (STD). FOR CW ROTATION, INTERCHANGE 5 AND 8.
 2. ROTATION CONNECTIONS

	JOIN	JOIN	ROT.	
STD.	9, 8	J, 5	CCW	
OPP.	9, 5	J, 8	CW	

PART NO.	SPEC. NO.	HP	RPM	VOLT	HZ	PH	F. L. AMPS
169656	36H633W566G1	3	3450	115/208-230	60	1	27.2/14.5-13.6

Diagram 16 – Wiring Diagram 3 hp/ 230V/460V /3 Phase/60 Hz Motor (000806)

Contact Factory For Wiring Diagram

Diagram 17 – Wiring Diagram 7.5 hp / 230V / 3 Phase / 60 Hz Motor (001265)
 (Ref: Dwg B-182128)

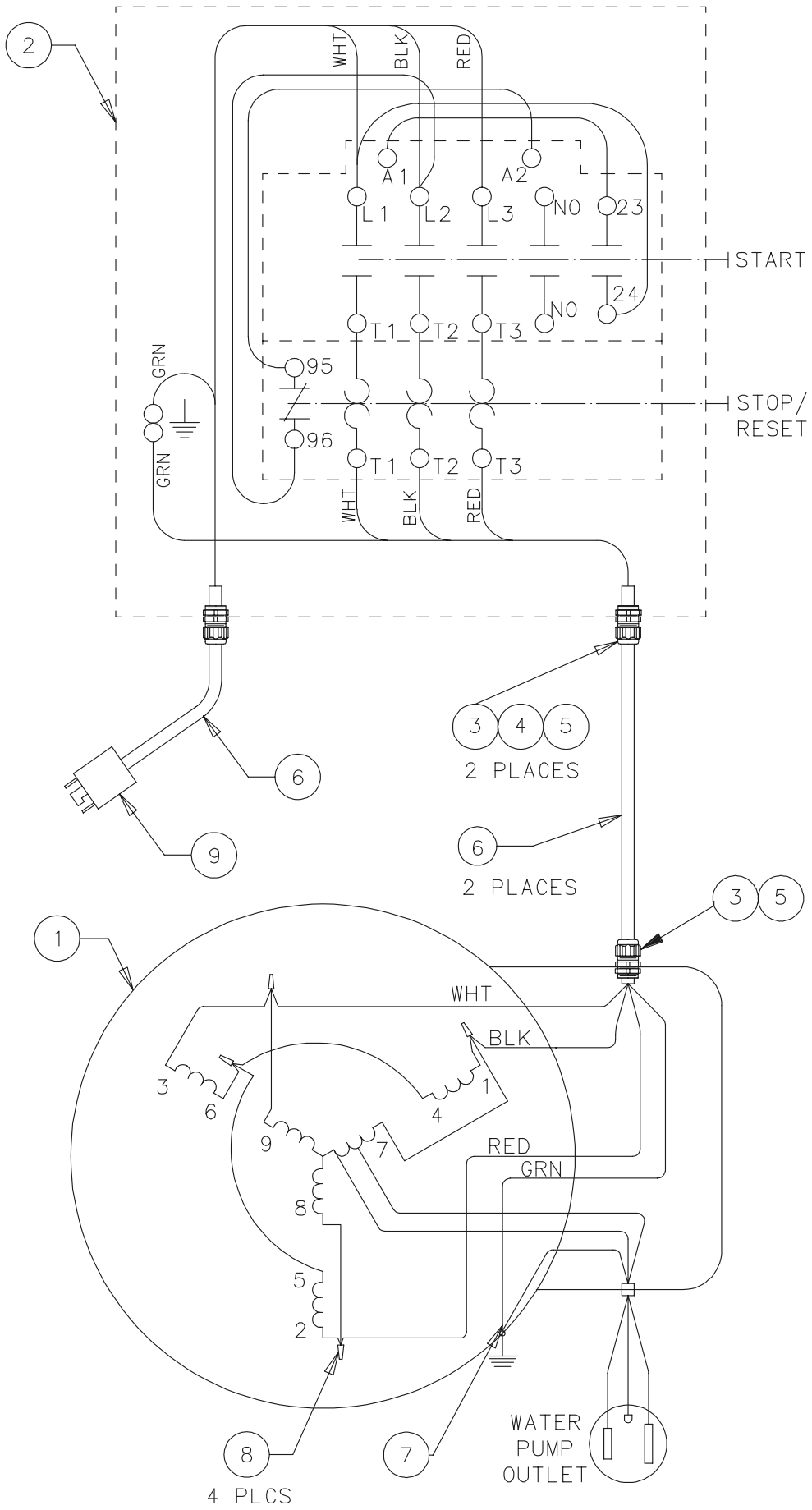

Diagram 17 – Parts List 7.5 hp / 230V / 3 Phase / 60 Hz Motor

(Ref: Dwg B-182128)

ITEM	P/N	DESCRIPTION	QTY
1	001265	Motor, 7.5hp/230V/3ph/60hz/19.4A	1
2	190103	Motor Starter	1 (Note 9)
3	182024	Strain Relief, 3/4 NPT	3
4	176953	Locknut, 3/4 Conduit	3
5	176933	Sealing Ring, 3/4 Conduit	2
6	182018	Cord, Type SO - 12/4 x 38 (To motor)	3.17 Ft
-	182018	Cord, Type SO - 12/4 x 42 (To plug)	3.50 Ft
7	182021	Terminal Ring, Insulated #10 x 12-10GA	1
8	090556	Connector, Wire, Yellow, 18-10 AWG	6
9	-----	Plug, Customer Supplied	1

NOTES:

9. When replacing the motor starter, adjust the overload protection (remove cover of box) to the same value as the Full Load Amp Value (Marked on the Motor Serial Number Plate).

Diagram 18 – Wiring Diagram 7.5 hp / 460V / 3 Phase / 60 Hz Motor (001265)

(Ref: Dwg B-182129)

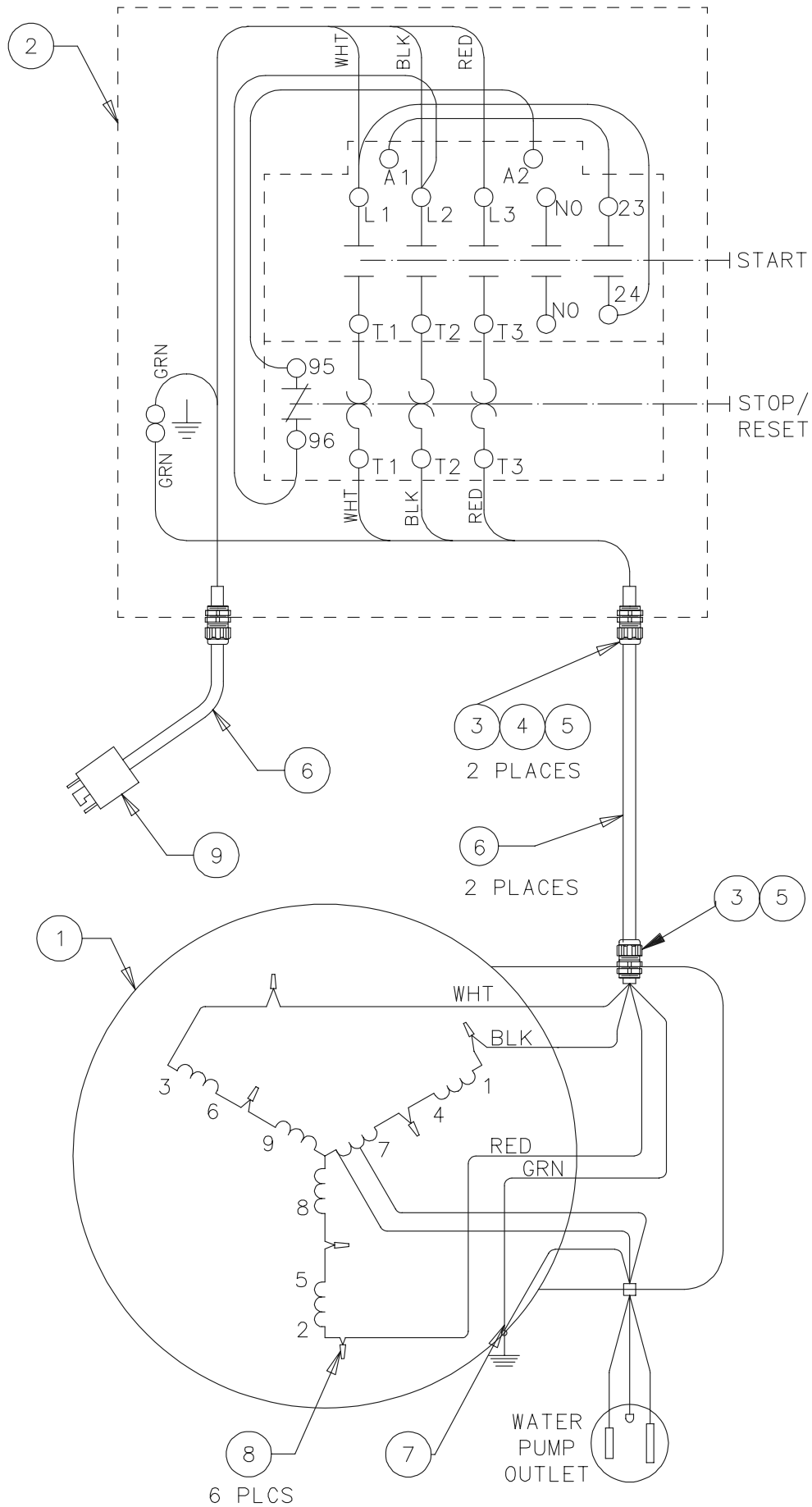

Diagram 18 – Parts List 7.5 hp / 460V / 3 Phase / 60 Hz Motor

(Ref: Dwg B-182129)

ITEM	P/N	DESCRIPTION	QTY
1	001265	Motor, 7.5hp/460V/3ph/60hz/9.7A	1
2	190102	Motor Starter	1 (Note 10)
3	182024	Strain Relief, 3/4 NPT	3
4	176953	Locknut, 3/4 Conduit	3
5	176933	Sealing Ring, 3/4 Conduit	2
6	182018	Cord, Type SO - 12/4 x 38 (To motor)	3.17 Ft
-	182018	Cord, Type SO - 12/4 x 42 (To plug)	3.50 Ft
7	182021	Terminal Ring, Insulated #10 x 12-10GA	1
8	090556	Connector, Wire, Yellow, 18-10 AWG	6
9	-----	Plug, Customer Supplied	1

NOTES:

10. When replacing the motor starter, adjust the overload protection (remove cover of box) to the same value as the Full Load Amp Value (Marked on the Motor Serial Number Plate).

Diagram 19 – Wiring Diagram 7.5 hp / 575V-60 Hz & 415V-50 Hz Motor

(Ref: Dwg B-182133)

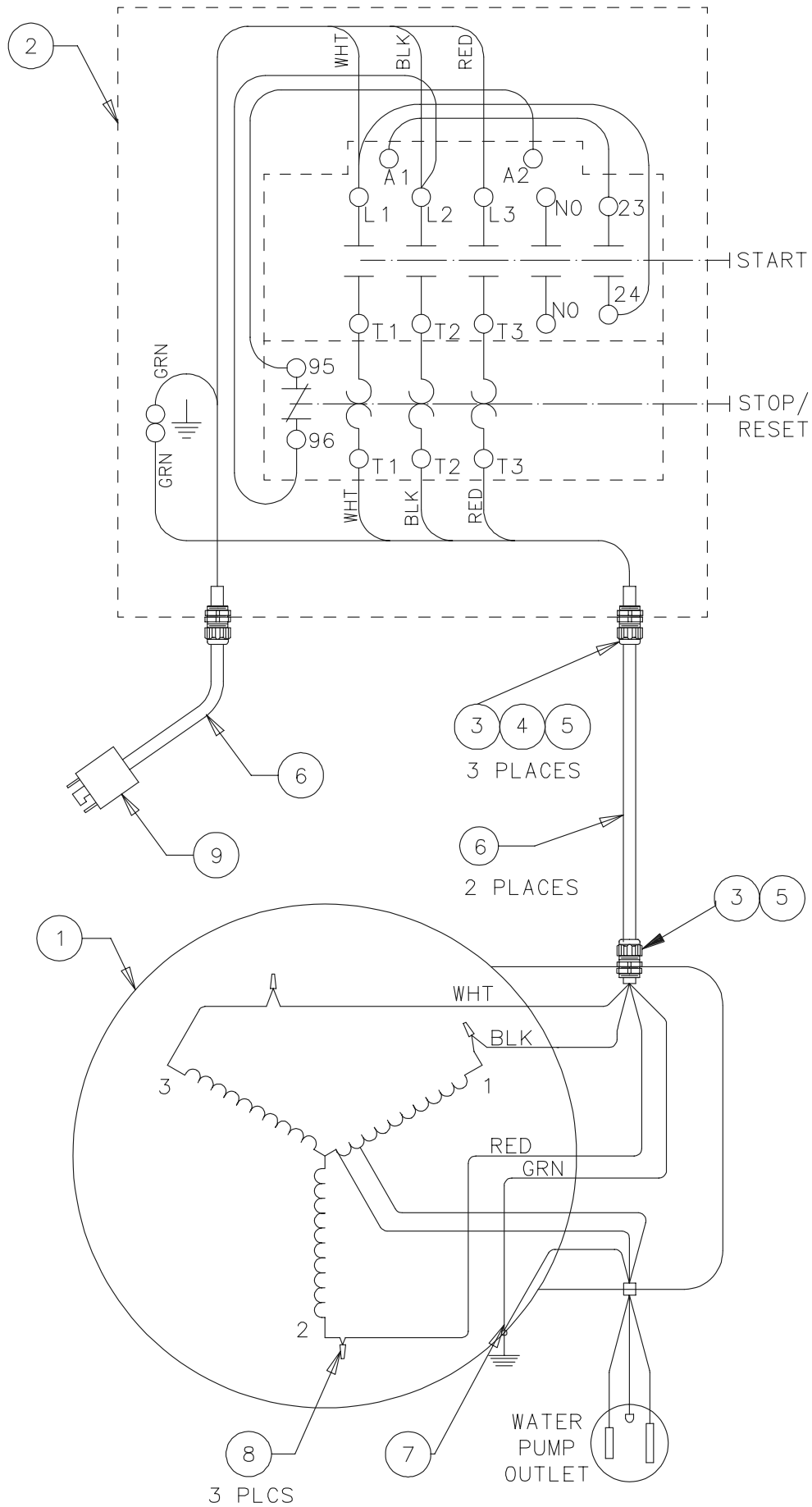

Diagram 19 – Parts List

7.5 hp / 575V / 3 Phase / 60 Hz Motor (Ref: Dwg B-182133)

ITEM	P/N	DESCRIPTION	QTY
1	001257	Motor, 7.5hp/575V/3ph/60hz/7.4A	1
2	186252	Motor Starter	1 (Note 11)
3	182024	Strain Relief, 3/4 NPT	3
4	176953	Locknut, 3/4 Conduit	3
5	176933	Sealing Ring, 3/4 Conduit	2
6	182018	Cord, Type SO - 12/4 x 38 (To motor)	3.17 Ft
-	182018	Cord, Type SO - 12/4 x 42 (To plug)	3.50 Ft
7	182021	Terminal Ring, Insulated #10 x 12-10GA	1
8	090556	Connector, Wire, Yellow, 18-10 AWG	3
9	-----	Plug, Customer Supplied	1

NOTES:

- When replacing the motor starter, adjust the overload protection (remove cover of box) to the same value as the Full Load Amp Value (Marked on the Motor Serial Number Plate).

7.5 hp / 415V / 3 Phase / 50 Hz Motor (Ref: Dwg B-182130)

ITEM	P/N	DESCRIPTION	QTY
1	162287	Motor, 7.5hp/415V/3ph/50hz/10A	1
2	190102	Motor Starter	1 (Note 12)
3	182024	Strain Relief, 3/4 NPT	3
4	176953	Locknut, 3/4 Conduit	3
5	176933	Sealing Ring, 3/4 Conduit	2
6	182018	Cord, Type SO - 12/4 x 38 (To motor)	3.17 Ft
-	182018	Cord, Type SO - 12/4 x 42 (To plug)	3.50 Ft
7	182021	Terminal Ring, Insulated #10 x 12-10GA	1
8	090556	Connector, Wire, Yellow, 18-10 AWG	3
9	-----	Plug, Customer Supplied	1

NOTES:

- When replacing the motor starter, adjust the overload protection (remove cover of box) to the same value as the Full Load Amp Value (Marked on the Motor Serial Number Plate).

Diagram 20 – Wiring Diagram 7.5 hp / 220V / 3 Phase / 50 Hz Motor (001270)

(Ref: Dwg B-182131)

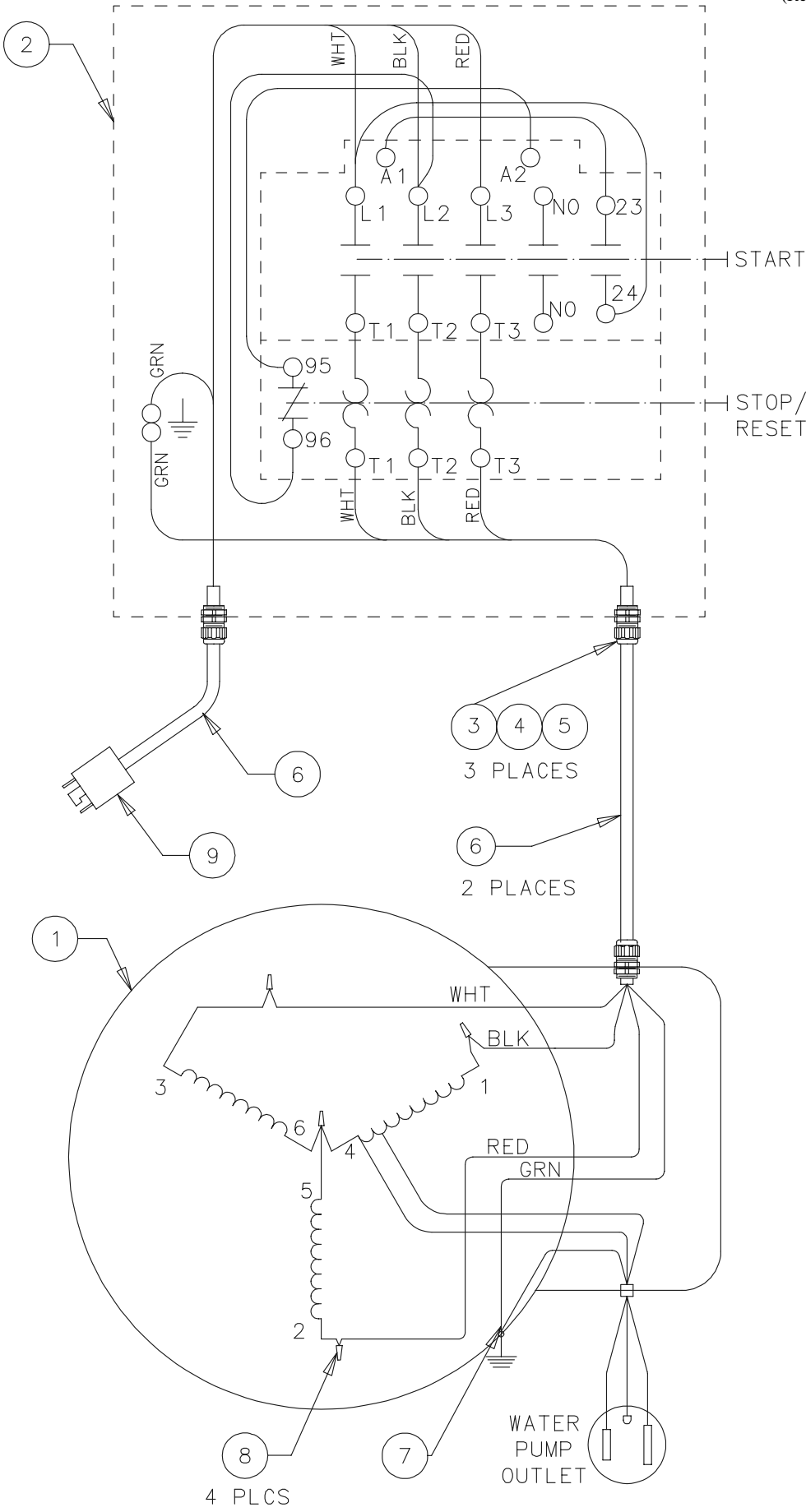

Diagram 20 – Parts List 7.5 hp / 220V / 3 Phase / 50 Hz Motor

(Ref: Dwg B-182131)

ITEM	P/N	DESCRIPTION	QTY
1	001270	Motor, 7.5hp/220V/3ph/50hz/18A	1
2	190103	Motor Starter 220V	1 (Note 13)
3	182024	Strain Relief, 3/4 NPT	3
4	176953	Locknut, 3/4 Conduit	3
5	176933	Sealing Ring, 3/4 Conduit	2
6	182018	Cord, Type SO - 12/4 x 38 (To motor)	3.17 Ft
-	182018	Cord, Type SO - 12/4 x 42 (To plug)	3.50 Ft
7	182021	Terminal Ring, Insulated #10 x 12-10GA	1
8	090556	Connector, Wire, Yellow, 18-10 AWG	4
9	-----	Plug, Customer Supplied	1

NOTES:

13. When replacing the motor starter, adjust the overload protection (remove cover of box) to the same value as the Full Load Amp Value (Marked on the Motor Serial Number Plate).

Diagram 21 – Parts List 7.5 hp / 380V / 3 Phase / 50 Hz Motor (001270)
 (Ref: Dwg B-182132)

ITEM	P/N	DESCRIPTION	QTY
1	001270	Motor, 7.5hp/380V/3ph/50hz/10.5A	1
2	190102	Motor Starter	1 (Note 14)
3	182024	Strain Relief, 3/4 NPT	3
4	176953	Locknut, 3/4 Conduit	3
5	176933	Sealing Ring, 3/4 Conduit	2
6	182018	Cord, Type SO - 12/4 x 38" (To motor)	3.17 Ft
-	182018	Cord, Type SO - 12/4 x 42" (To plug)	3.50 Ft
7	182021	Terminal Ring, Insulated #10 x 12-10GA	1
8	090556	Connector, Wire, Yellow, 18-10 AWG	3
9	-----	Plug, Customer Supplied	1

NOTES:

- When replacing the motor starter, adjust the overload protection (remove cover of box) to the same value as the Full Load Amp Value (Marked on the Motor Serial Number Plate).